

**RECOMMENDED OPERATING, CARE AND INSPECTION MANUAL**

*For*

# **Polyester and High Performance Yarn Roundslings**

**WSTDA-RS-2**



## MANDATORY AND ADVISORY RULES

Mandatory rules are characterized by the use of the words "must" or "shall". If a rule is of an advisory nature, it is indicated by the use of the word "should", or it is stated as a recommendation.

The Web Sling & Tie Down Association has also formulated a ***Recommended Standard Specification for Synthetic Polyester Roundslings - WSTDA RS-1***, and for ***High Performance Yarn Roundslings WSTDA - RS-1HP*** as a guide for users, industry and government to ensure the proper use, maintenance and inspection of roundslings.

The Association respectfully suggests the use of WSTDA RS-1 and RS-1HP by all roundsling users.



**Web Sling & Tie Down Association, Inc.**

2331 Rock Spring Road  
Forest Hill, Maryland 21050 U.S.A  
Phone (443) 640-1070  
Fax (443) 640-1031  
Web Site [www.wstda.com](http://www.wstda.com)

First published and copyright © 1996

First Revision 2005

Second Revision 2019

# TABLE OF CONTENTS

<b>INTRODUCTION</b> .....	<b>1</b>
Web Sling and Tie Down Association .....	1
Training Requirements .....	2
<b>CHAPTER 1: ROUNDSLING GENERAL INFORMATION</b> .....	<b>3</b>
Section 1.1 Roundslings .....	3
Section 1.2 Sling Selection Considerations .....	3
Section 1.3 Roundsling Identification .....	4
<b>CHAPTER 2: PROPER LIFTING PRACTICES</b> .....	<b>5</b>
Section 2.1 Common Sling Hitches .....	5
2.1.1 Vertical Hitch .....	5
2.1.2 Choker Hitch .....	6
2.1.3 Double Wrapped Choker Hitch .....	6
2.1.4 Basket Hitch .....	7
2.1.5 Double Wrapped Basket Hitch .....	7
2.1.6 Bridle Hitch, Multi-Leg .....	8
2.1.7 The Adjusting Hitch (For Polyester Roundslings) .....	8
Section 2.2 Proper Use of Sling Hitches .....	9
2.2.1 Assessing the Load.....	9
2.2.2 Load Control, Balance and Stability.....	9
2.2.3 Using Single Leg Hitches .....	10
2.2.4 Using Double Wrap Hitches .....	14
2.2.5 Effect of Choker Hitch Angle .....	14
2.2.6 Using Double Choker Hitches .....	15
2.2.7 Hitching for Load Turning.....	16
2.3 Effect of Sling Angles .....	18
2.3.1 Increased Sling Tension Method (Recommended).....	19
2.3.2 Sling Lift Capacity Reduction Method (Alternative).....	20
<b>CHAPTER 3: MAINTAINING PROPER CLEARANCE</b> .....	<b>21</b>
<b>CHAPTER 4: ROUNDSLING INSPECTION</b> .....	<b>22</b>
Section 4.1 Inspection Procedure.....	22
Section 4.2 Removal from Service Criteria.....	22
Section 4.3 Frequency of Sling Inspections .....	23
<b>CHAPTER 5: ROUNDSLING OPERATING PRACTICES</b> .....	<b>25</b>
Section 5.1 Roundsling Rated Capacities .....	25
Section 5.2 Choosing Proper Connection Hardware (Polyester Roundslings).....	27
Section 5.3 Bearing Stress Calculations for Polyester Roundslings.....	29

Section 5.4 Protecting Roundslings from Being Cut or Damaged from Contact with Edges.....	33
Section 5.5 When do Roundslings Need Cut Protection? .....	33
Section 5.6 What Form of Cut Protection is Suitable?.....	36
Section 5.7 Other Mechanical Considerations .....	37
Section 5.8 Environmental Considerations.....	39
<b>CHAPTER 6: ROUNDSLING REPAIR.....</b>	<b>41</b>
<b>CHAPTER 7: SLING STORAGE AND MAINTAINANCE .....</b>	<b>42</b>
<b>WEB SLING &amp; TIE DOWN ASSOCIATION PUBLICATIONS .....</b>	<b>43</b>

# INTRODUCTION

## Web Sling and Tie Down Association

The Web Sling & Tie Down Association (WSTDA) is a tax-exempt, non-profit, technical association dedicated to the development and promotion of voluntary recommended standards and associated reference materials. Originally established in 1973 as the Web Sling Association (WSA), the WSA serviced the synthetic web sling industry. In 1988, the WSA further defined its purpose to include synthetic web tie downs and became the Web Sling & Tie Down Association.

Today, members of the WSTDA include manufacturers and suppliers of synthetic web slings and tie downs, roundslings, synthetic webbing, fibers, thread and related components. These products are used in the manufacturing, transportation, recreation, and forestry industries; also by the military and governmental agencies, for lifting, suspending, transporting, lowering, and other load handling under known conditions.

The WSTDA's mission is to foster and further, in every lawful manner, the common interests of its members and industry. In pursuance of this mission, the association has prepared this manual.

Accordingly, the Web Sling & Tie Down Association, Inc. disclaims any responsibility for the actual use of any synthetic roundsling products.

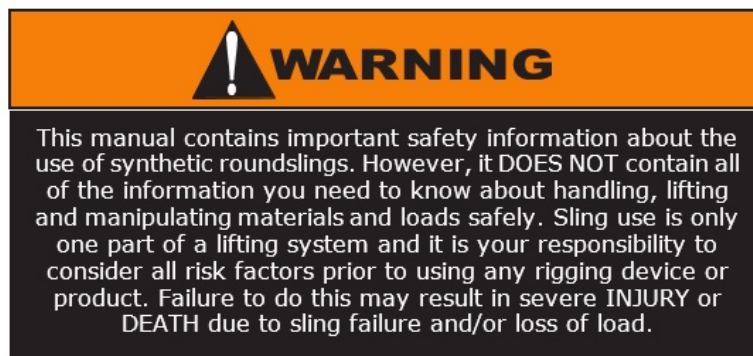

Users should also consult the manufacturer of such products for further information concerning the proper use and care of their products.

## Training Requirements

Safety is the paramount consideration involved in the use of any sling.

If you are unsure whether you are properly trained and knowledgeable, or if you are unsure of what the standards and regulations require of you, ask your employer for information and/or training – DO NOT use slings until you are absolutely sure of what you are doing. Remember, when it comes to using slings, lack of skill, knowledge and care can result in severe INJURY or DEATH to you and others.

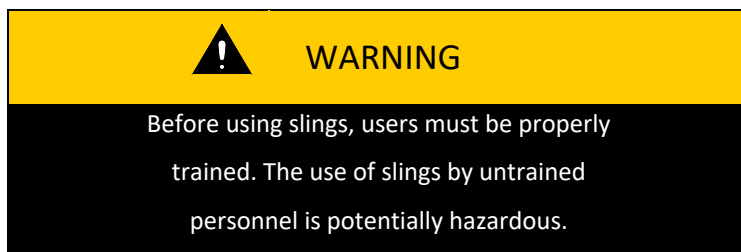

**All users must be trained** in the following areas.

The following six points briefly summarize some important safety issues.

- *Sling Selection* – Understand the limitations of each sling type and their associated rigging materials.
- *Sling Inspection* – Understand how to properly inspect slings, so damaged slings can immediately be removed from service.
- *Prevention of Sling Damage* – Know how to prevent sling damage, including how to properly protect them from being cut or damaged from direct contact with corners, edges, protrusions, or abrasive services.
- *Proper Use of Slings* – Each sling user shall be competent in considering all risk factors prior to lifting a load, and be able to verify that each sling will not be loaded in excess of its rated capacity.
- *Maintain Proper Clearance When Lifting Loads* – Whenever using slings, all personnel shall be trained to remain alert, and stand clear of any lifted load and outside of the *Danger Zone*.
- *Proper storage of slings* – Users should know where to store slings in an environment where they will not become damaged, such as by exposure to heat, chemicals, and sunlight, or other UV Light.

Users should also read, understand and follow the information provided with each sling as well as applicable state, federal and OSHA regulations. Additional guidelines covering the use of roundslings are contained in ASME B30.9, WSTDA RS-1 and RS-1HP standards.

# CHAPTER 1: ROUNDSLING GENERAL INFORMATION

## Section 1.1 Roundslings

A roundsling, as represented in Figure 1, is a type of sling used for general lifting or material handling purposes that is comprised of a load-bearing core(s), made from synthetic yarns of unwoven continuous filament fibers, which is fully enclosed in a protective cover(s). This document provides information regarding the inspection and operation of polyester and high-performance yarn (HPY) roundslings.

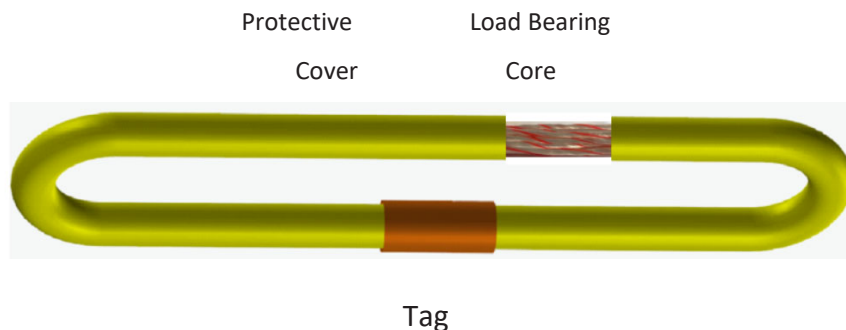

Figure 1 – Roundsling

Safety is the paramount consideration involved in the use of any roundsling. The proper roundsling must be chosen for the job. Riggers must know the proper hitch to use, where and how to attach roundslings to the load. Therefore, riggers shall acquire the knowledge, not only of the different type hitches, but the way loads can be expected to react when the lift is made.

When lifting loads, a trained, qualified and knowledgeable user must take into account the factors and issues addressed in this manual, as well as consider any other relevant factors not addressed herein (see also Table 13). Among the factors related specifically to roundslings, users must perform several activities, including (but not limited to) those discussed in the following subsections.

## Section 1.2 Sling Selection Considerations

Select a sling having suitable characteristics for the type, size and weight of the load, while also considering the method of rigging and the environment. The sling must be securely attached to the load and rigged in a manner to provide for load control to prevent slipping, sliding and/or loss of the load. A trained, qualified and knowledgeable user must determine the most appropriate method of rigging to help ensure a safe lift and control of the load.

Some **Positive Features** of roundslings include the following:

- *Handling* – Roundslings are Lightweight, flexible, and easy to rig
- *Elongation* - Polyester and high-performance (HPY) yarn roundslings elongate approximately 3% and 1% at a rated capacity, respectively, which is less than nylon and polyester webbing slings
- *Durability* - Wear points can be easily rotated to extend sling life
- *Protective Cover Material* - The exterior cover aids in protecting the load bearing core yarn
- *Inspection* - Roundslings are relatively easy to inspect
- *Condition of Load Surfaces* - Roundslings are less damaging to contacting load surfaces than metal type slings

Some Notable Roundsling **Limitations**:

- *Edge Cutting* - Roundslings can be cut by contact with unprotected edges
- *Temperature Limit* – Roundslings typically have a lower operating temperature limit when compared with sling types made from steel.
- *Draining from exposure to Liquids* - Depending on the cover material and construction, liquids may tend to accumulate and drain slowly from the cover when being used in wet operations

### **Section 1.3 Roundsling Identification**

Each roundsling shall have a tag or be durably marked or labeled showing:

- a. *Rated capacity values* for:
  - The three basic hitches (*Vertical, Choker, Vertical Basket*) for single leg slings.
  - The use at angles of 60, 45, and 30 degrees from the horizontal for multi-leg bridle slings.
  - The designated hitch of intended use for special applications.
- b. *Length (reach)* – bearing point to bearing point
- c. *Core fiber type* – If the cover(s) is of a different fiber type, both fiber types shall be identified.
- d. *Name or trademark of manufacturer*
- e. *Manufacturer’s code or stock number*
- f. *The number of legs*, if more than one.

## CHAPTER 2: PROPER LIFTING PRACTICES

Information provided in this section, unless noted otherwise, applies in general to most types of slings. In addition to the descriptions found in this section, definitions for many of the terms noted in this document may be found in WSTDA Roundsling standards RS-1 and RS-1HP standards.

### Section 2.1 Common Sling Hitches

Loads vary in physical dimension, shape and weight. Where and how to attach slings is important to a rigger, as it can impact many factors including sling tension, overhead clearance, load stability and control and damage to load surfaces.

#### 2.1.1 Vertical Hitch

A method of rigging, shown in Figure 2, in which the load is attached to one end of the sling, such as by means of a hook or shackle, and the other end of the sling is attached to the lifting device. This hitch is sometimes also called a straight-line hitch.

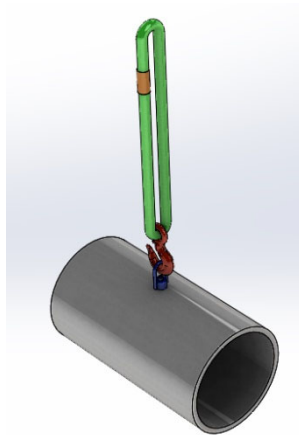

Figure 2

### **2.1.2 Choker Hitch**

A method of rigging, shown in Figure 3, in which the sling is passed around the load and then through itself and then attached to the lifting device.

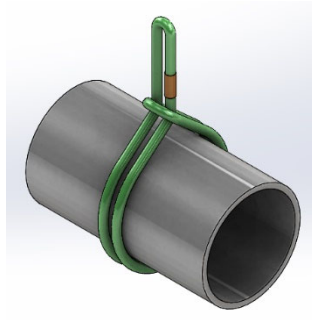

Figure 3

### **2.1.3 Double Wrapped Choker Hitch**

A method of rigging, shown in Figure 4, in which the sling is passed around the load twice and then through itself, and then attached to the lifting device. The double wrap hitch or the double wrap choker hitch provides full 360 degree contact with the load.

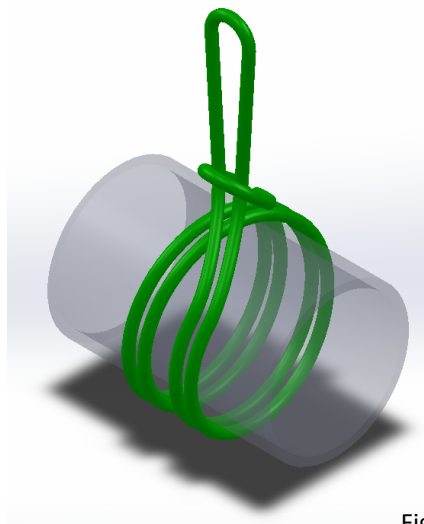

Figure 4

### **2.1.4 Basket Hitch**

A method of rigging, shown in Figure 5, in which the sling is passed around the load and both ends are attached to the lifting device.

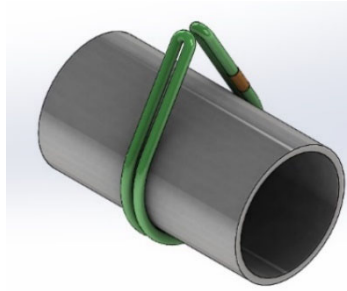

Figure 5

### **2.1.5 Double Wrapped Basket Hitch**

A method of rigging, shown in Figure 6, similar to the basket hitch except that the sling is passed around the load twice.



Figure 6

### 2.1.6 Bridle Hitch, Multi-Leg

A method of rigging, shown in Figure 7, as a 2-leg bridle, in which the load is attached to the legs of a bridle assembly. 2, 3 and 4-leg slings are commonly used types of bridle slings.



Figure 7

### 2.1.7 The Adjusting Hitch (For Polyester Roundslings)

A method of rigging, shown in Figure 8, which is suitable for use *polyester roundslings* is the adjusting hitch. (For HPY roundslings, consult the sling manufacturer.)

The effective length of the adjusting hitch can be easily changed to suit job conditions, but once the weight is applied to the sling, no further change in length occurs. It is particularly useful when lifting an object that has one end heavier than the other. The adjusting hitch makes it fairly easy to adjust the length of the sling or the legs of a bridle to maintain a level load. **When using the adjusting hitch, the sling shall not be loaded in excess of the sling's vertical hitch rated capacity.**



Figure 8

## **Section 2.2 Proper Use of Sling Hitches**

### ***2.2.1 Assessing the Load***

Determine the weight of the load and make sure the sling's rated capacity or the capacity of any of the components of the rigging system will not be exceeded.

### ***2.2.2 Load Control, Balance and Stability***

Loads must be lifted in a well-controlled manner. Various factors can influence load control including:

- Size, Shape and Weight Distribution of the Load
- Structural and Weight Stability of the Load
- Surface Condition and Frictional Properties of Contact Surfaces
- Method of Sling Connection / Sling Hitch Selection
- Number of Slings
- Sling Angle

Perform tests lifts as needed to verify load control stability whenever load control is uncertain.

Users must also determine the load's center of gravity (CG). The load's CG will always position itself under the lifting device during lifting operations. Use a hitch that will keep the load under control at all times and, to avoid swinging of the load, be sure the lifting device is directly over center of gravity (CG) prior to starting the lift. Lift the load carefully, accelerating smoothly and avoid shock loading.

### 2.2.3 Using Single Leg Hitches

Users must consider that single sling hitches may not provide optimum control over the load, as shown in Figure 9. This is especially true whenever they are attached below the center of gravity. In these hitches only one sling supports the load.

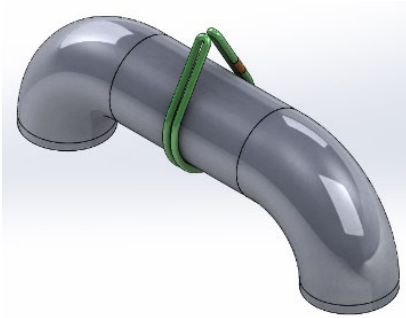

Figure 9  
Poor Stability

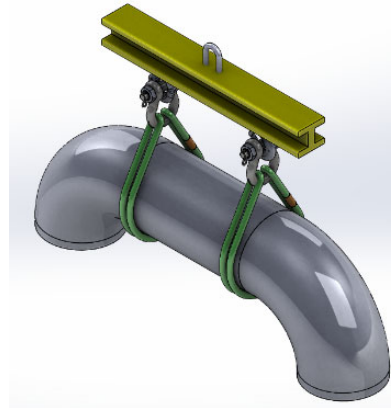
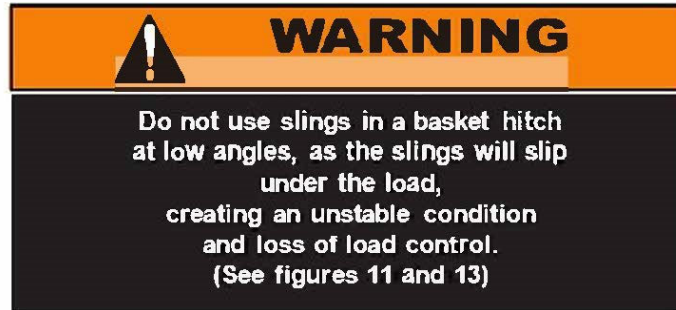

Figure 10  
Good Stability

*Maintaining Load Balance Example*

*Using Basket Hitches* - Basket hitches, whether single or double, may be used successfully in a variety of applications.



*Note:* When using 2 or more slings in a basket hitch, consider that the tendency for slippage will increase as the sling angle is reduced.

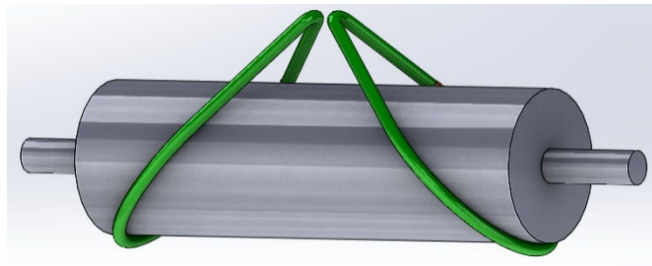

Figure 11  
Stability is reduced as the angle is  
decreased

*Other Load Stability Examples* - Whenever loads are rigged such that the stability of a hitch relies on friction between the sling and load surfaces, the chosen sling angle can impact stability of the load during a lift. Increase the sling angle as needed, as the load stability will improve as the angle is increased. The minimum angle where stability is maintained will depend on the amount of grip (frictional properties) between the sling and load surfaces.



Figure 12  
Not reliant on Friction  
Very Stable Method

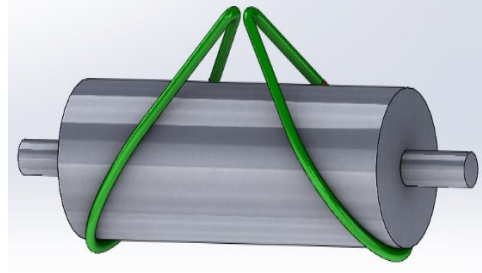

Figure 13  
Reliant on Friction  
Potentially a Less Stable Method

*Sling Stability at the Hoist Connection* - To prevent possible loss of load control, also avoid using hitches that can allow the sling(s) to slide through the hoisting hook or top attachment point, particularly when the load weight is unevenly distributed.

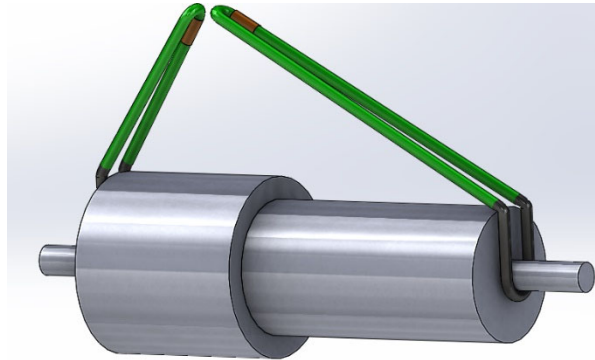

Figure 14 Preferred Way

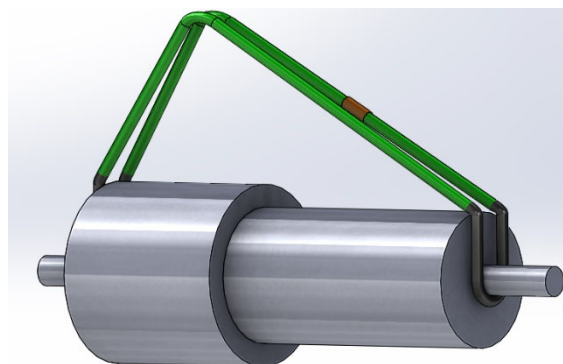

Figure 15 Less Stable Way

### 2.2.4 Using Double Wrap Hitches

Double wrap hitches such as the double wrap choker hitch may be used to help provide improved control over the load. With this single hitch, part of the sling is in full 360 degree contact with the load being lifted.

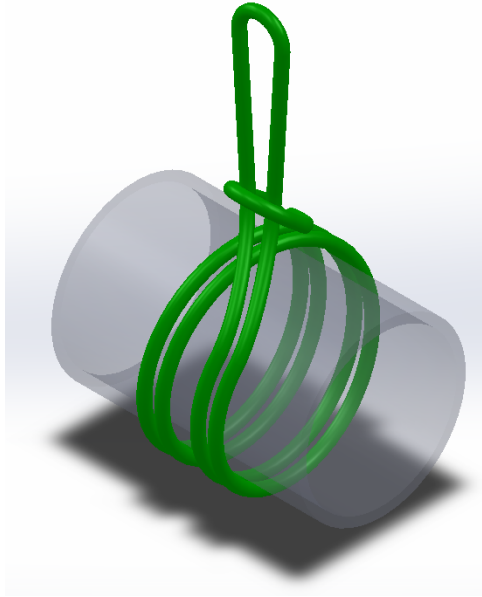

Figure 16

### 2.2.5 Effect of Choker Hitch Angle

When the angle of choke is less than 120 degrees, the sling choker hitch capacity is affected. One application that commonly yields reduced choker hitch angles is the turning of loads with the angle being reduced as the load is rotated. To determine the actual choker capacity at a given angle of choke, simply multiply the sling choker rating by the appropriate reduction factor determined from Table 1. (See Figure 17).

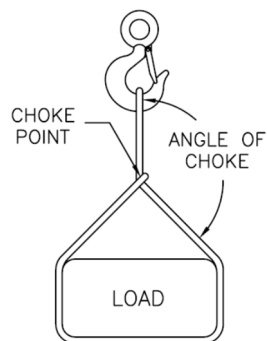

Figure 17

**Table 1. Choker hitch Angle Factor**

Angle of Choke (Degrees)		Angle of Choke Reduction Factor
Equal to or greater than	Less Than	
120	180	1.00
105	120	0.82
90	105	0.71
60	90	0.58
0	60	0.50

### **2.2.6 Using Double Choker Hitches**

The double choker hitch is sometimes selected for use rather than the basic choker hitch because it is twice as strong as a single choker hitch in the same sling type.

When this hitch is done properly, as shown in Figure 18, both legs will automatically equalize over the crane hook. On the other hand, when it is made improperly, only a single choker capacity is acceptable as the two legs will not tend to equalize, as shown in Figure 19.

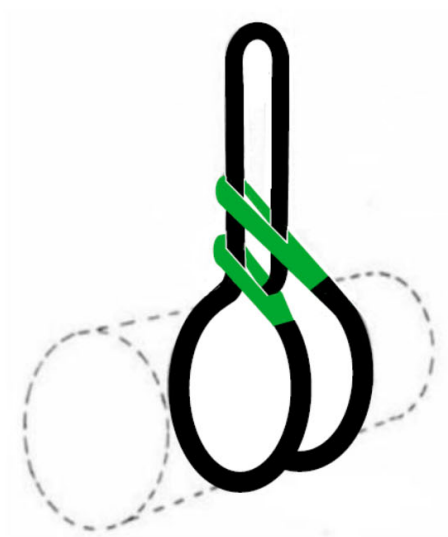

Figure 18

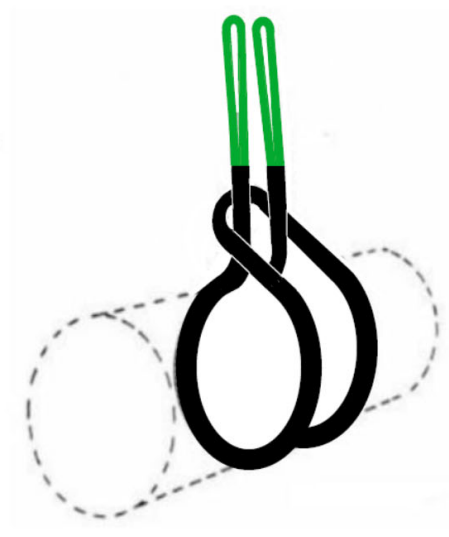

Figure 19

### **2.2.7 Hitching for Load Turning**

When turning loads, heavy abrasive damage to the sling can occur where it contacts the load surfaces and edges if sliding occurs between the sling and load surfaces.

To help preserve the condition of the sling, riggers will commonly want to use a choker hitch, or double wrap choker hitch, for this purpose. If the choker hitch is oriented in the manner shown in Figure 20, the sling hitch will remain tight onto the load as it is being turned, which can reduce the movement or scrubbing of the sling.

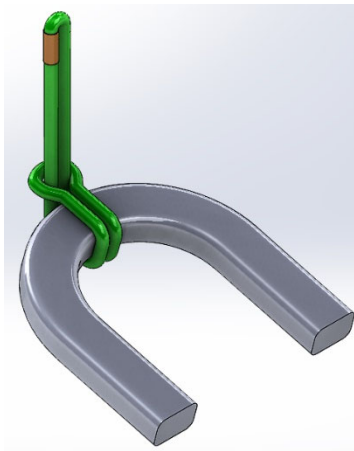

Figure 20  
(Showing load position  
prior to load turning)

Alternatively, if a choker hitch is oriented in the opposing direction, the hitch will loosen as the load is being turned. This may allow the sling to scrub against the load surface and possibly damage the sling if it is not suitably protected.

(See Figure 21.)

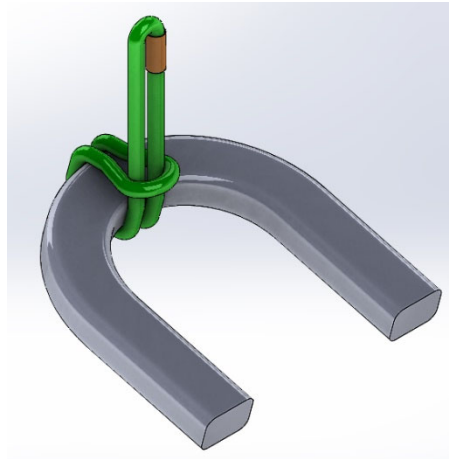

Figure 21

Similarly, if a basket hitch is employed, the sling may slide against the load surface and damage the sling if it is not suitably protected.

(See Figure 22.)

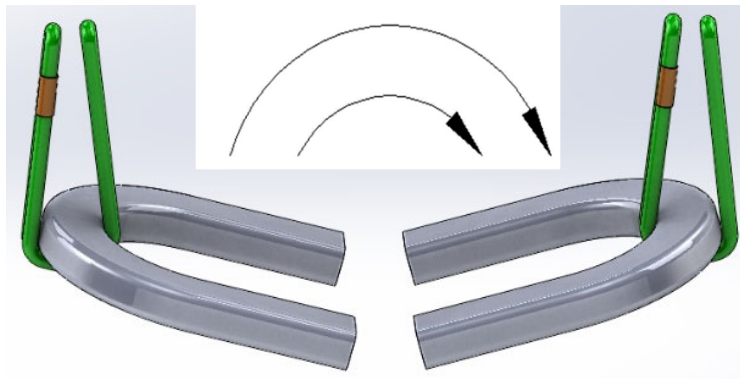

Figure 22

## Using Multi-Leg Bridle Slings

The *Rated Capacities for Multi-leg Bridle* assemblies are based on a set of ideal conditions as follows:

1. The load is evenly distributed on all legs.
2. All legs are the same length
3. All legs are used at the same sling angle.

*Note on Multi-leg Bridle Slings with 4 or more legs:* Sling users should consider, for example when using a 4-leg bridle, that 2 of the legs may bear most or all the loading whenever the loading is not evenly distributed.

If the conditions of the lift vary from those above, the rated capacity must be individually calculated for each leg by a qualified person.

## 2.3 Effect of Sling Angles

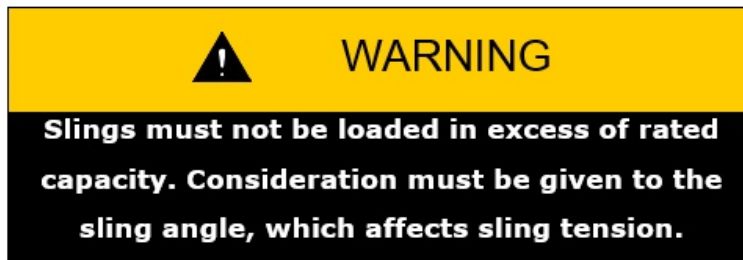

Sling tensions are affected by angle of lift (sling angle) when they are used with multi-legged roundslings or choker/basket hitches. Sling angles are measured from the horizontal (See Figure 23). The effect of this angle may be addressed by using either of two methods:

- Increased Tension Method (Recommended Method)
- Reduced Sling Capacity Method (Alternative method)

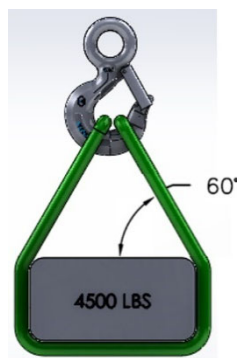

Figure 23

### 2.3.1 Increased Sling Tension Method (Recommended)

This method calculates the actual amount of tension being applied to each sling. To use this method, the user must:

1. Determine the load weight.
2. Determine the sling angle, as measured from the horizontal, and the corresponding tension factor. (From Table 2).
3. Determine the share of the load applied to each sling leg.
4. Multiply the sling leg's share of the load by the tension factor to determine the sling leg tension.
5. The capacity of the selected sling must meet the calculated tension value.

**Table 2. Effect of Sling Angle – Tension Factor Chart**

Angle in Degrees from Horizontal	Tension Multiplier	Angle in Degrees from Horizontal	Tension Multiplier
90	1.000	55	1.221
85	1.004	50	1.305
80	1.015	45	1.414
75	1.035	40	1.555
70	1.064	35	1.742
65	1.104	30	2.000
60	1.155		

*Example* – If a load weighing 10,000 Lbs. is lifted in a basket hitch, the sling tension will increase as the sling angle decreases.

See the Table 3.

**Table 3. Example of the effect of Sling Angle on Tension**

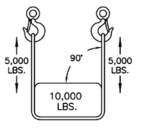
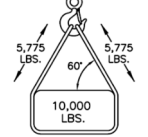
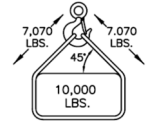
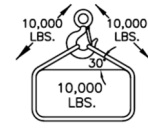
Tension in the Sling Increases as the Sling Angle Decreases				
Sling Angle (from Horizontal)	90°	60°	45°	30°
Tension Multiplier	1.00	1.155	1.414	2.000
Sling Leg Tension (Lbs. Per Leg)	5,000	5,775	7,070	10,000
Required Sling Basket Capacity (Lbs.)	10,000	11,550	14,140	20,000

### 2.3.2 Sling Lift Capacity Reduction Method (Alternative)

This method calculates the adjusted vertical lift capacity for each sling. To use this method, the user must first determine the angle and multiply the sling capacity by the appropriate loss factor for the specific angle. The result is the *Reduced Sling Capacity*.

1. Determine the sling angle, as measured from the horizontal.
2. Determine the corresponding (sling capacity) loss factor (From Table 4)
3. Multiply the sling capacity by the loss factor to determine the actual sling capacity at the given angle of lift.

The result is the reduced sling capacity.

**Table 4. Effect of Sling Angle – (Sling Capacity) Loss Factor**

Angle in Degrees from Horizontal	Loss Factor	Angle in Degrees from Horizontal	Loss Factor
90	1.000	55	0.819
85	0.996	50	0.766
80	0.985	45	0.707
75	0.966	40	0.643
70	0.940	35	0.574
65	0.906	30	0.500
60	0.866		

*Example:* A polyester roundsling, size no.1 (purple), and rated at 5,200 lbs. in a vertical basket hitch rating, is being used in a basket hitch at a 60-degree angle. What is its lifting capacity at this lifting angle?

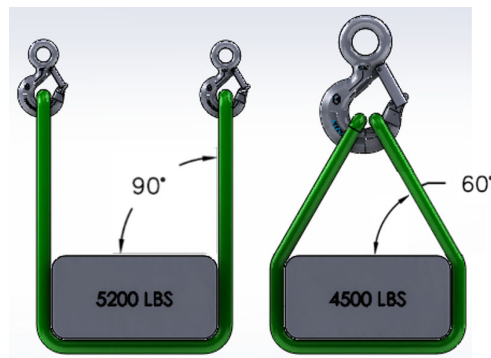

Figure 24

*Answer:* Its lifting capacity at a 60-degree lifting angle equals the basket hitch capacity times the angle factor, from Table 4, of .866 for a 60-degree angle.

$$5,200 \text{ lbs.} \times .866 = 4,500 \text{ lbs.}$$

## CHAPTER 3: MAINTAINING PROPER CLEARANCE

***Make Sure All Personnel are Clear of Loads and Alert to Risks, Especially in the “Danger Zone”*** – Even if you account for all of the factors/issues discussed in this Manual, things can still go wrong. Therefore, all personnel must be alert to potential risks associated with the use of roundslings, especially in the *Danger Zone*.

The *Danger Zone* is any area where (a) the load could fall on or swing into personnel or property, or (b) deadly recoil could be produced by an unplanned release of tension. Therefore:

- ***Stand Clear*** – All personnel must stand clear of lifted loads and never be under, on, or near suspended loads.
- ***Deadly Recoil*** – Personnel must not stand in-line with or next to rigging under tension. Any unplanned release of tension could strike personnel with deadly recoil force.
- ***Be Alert*** – Personnel must be alert to the potential for the sling and/or load to become snagged/hung-up during load handling.
- ***Pinch Points*** – Once load-handling activities begin, sling users must NEVER place any part of the body between the sling and the load or between the sling and hook/shackle/connection point and/or load-handling device.
- ***Never Ride*** – Personnel must never ride the sling or load.

**NEVER ON. NEVER UNDER. NEVER IN-LINE.**

***Planning*** – Preplan routes for the loads to help ensure that personnel will not be located within the *Danger Zone*.

***Receiving a Load*** – When a load is being landed, personnel must remain clear of the load until it is properly secure. Only in cases where it is absolutely essential that one or more workers, such as those hooking and/or unhooking of the load, must remain near the load in order for it to be properly secured shall they be permitted to be near the load during handling operations.

***Stationary Suspended Loads*** – When a suspended load is not being moved for an extended period, personnel must be restricted from entering the *Danger Zone*. Use barricades, caution lines and erect notices as needed for this purpose.

## CHAPTER 4: ROUNDSLING INSPECTION

### Section 4.1 Inspection Procedure

To detect possible damage, you should perform a visual inspection of the entire sling, and also feel along its entire length, as some damage may be felt more than seen. You should look and feel for any of the types of conditions listed in Table 5. Table 6 shows examples of some of these types of damage (Note: They are relatively extreme examples provided for illustration purposes only).

### Section 4.2 Removal from Service Criteria

If you identify ANY of these types of damage in a sling, **remove it from service immediately** even if the damage you feel or see is not as extensive as shown in the pictures in Table 6. Slings that are removed from service must be destroyed and rendered completely unusable unless they can be repaired and proof tested by the sling's manufacturer or other qualified person. You should never ignore sling damage or attempt to perform temporary field repairs of damaged slings (e.g., do not attempt to patch the cover sleeve damage if the core yarn is exposed, etc.).

**Table 5. Roundsling Removal From Service Criteria**

**Removal Criteria** - A roundsling shall be removed from service if any of the following forms of damage are visible:

- Holes, tears, cuts, embedded particles, excessive abrasive wear or snags that expose the core fibers of the roundsling.
- If roundsling identification tag is missing or notreadable.
- If roundsling has been tied into one or more knots or has been joined by knotting.
- Melting, charring or weld spatter of any part of the roundsling.
- Acid or alkali burns of the roundsling.
- Broken or worn stitching in the cover that exposes the core fibers.
- Distortion, excessive pitting, corrosion or other damage to fitting(s).
- Any evidence of a broken core yarn(s) present in the form of a substantial reduction of core yarn within any area of the roundsling and/or by a substantial accumulation of core yarn bundle within any section of the roundsling.
- Any conditions which cause doubt as to the strength of the roundsling.

Table 6

Types of Damage You Should Look and Feel for in Roundslings

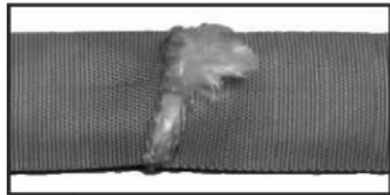

Holes/tears/cuts in cover;  
exposed/damaged yarns

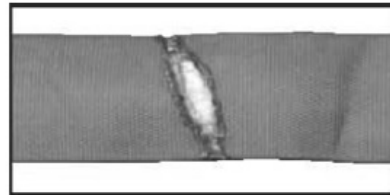

Melting or charring

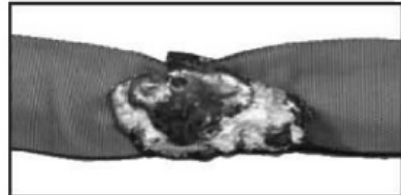

Acid/alkali burns

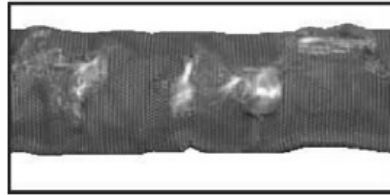

Snags/punctures



Weld spatter

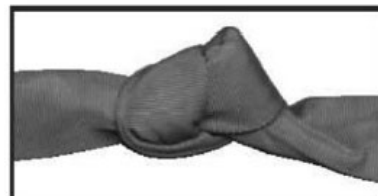

Knots

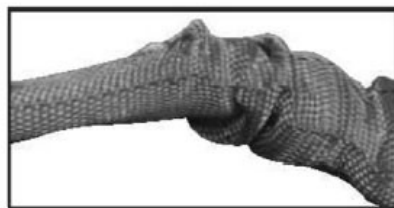

Bunched/wadded yarns

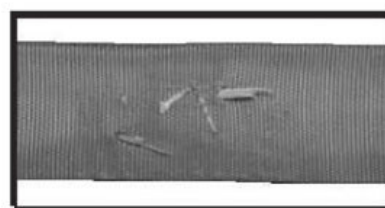

Embedded materials

### Section 4.3 Frequency of Sling Inspections

A three-stage procedure is recommended to help ensure that slings are inspected with appropriate frequency.

**Initial Inspection** – Whenever a sling is initially received, it must be inspected by a designated person to help ensure that the correct sling has been received and is undamaged and that the sling meets applicable requirements for its intended use.

**Frequent Inspection** – Roundslings must be inspected before each use for forms of damage listed in the Removal Criteria, shown in Table 5, by the user or other designated person. (Written records are not required for frequent

inspections.)

When roundslings are being used where they are not being exposed to any severe service conditions, the frequency of this sling inspection interval may be reduced to once each day or shift, done prior to sling use. A qualified person must be monitoring the application and to verify that the slings are not being exposed to any conditions that could cause a rapid rate of sling degradation during the work shift.

***Periodic Inspection*** – Every sling must be inspected “periodically” by a qualified and designated person. In order to validate the frequent level of inspection, the periodic inspection should be performed by someone other than the individual(s) who most commonly perform the frequent inspection. The frequency of periodic inspections is based on the sling’s actual or expected frequency of use, severity of service conditions, the nature of the work performed with the sling and experience gained during the inspection of other slings used in similar circumstances. General guidelines for the frequency of periodic inspections are:

*Normal Service* – yearly

*Severe Service* – monthly to quarterly

*Special service* – as recommended by a qualified person.

Periodic inspections intervals must not exceed one year.

***Written Records*** - A written record of the most recent periodic inspection must be maintained. It is not required that the condition of individual slings be recorded during the periodic inspection. If documentation of individual slings is maintained, it should be based upon a unique sling serial number, color coding or electronic tracking (RFID) or other means. If individual tracking is not maintained, the inspection process should provide some means of identifying which slings have been inspected at the periodic level of inspection.

# CHAPTER 5: ROUNDSLING OPERATING PRACTICES

## Section 5.1 Roundsling Rated Capacities

Be sure the roundsling you intend to use has an adequate rated capacity for the job (refer to identification and capacity tag on each sling).

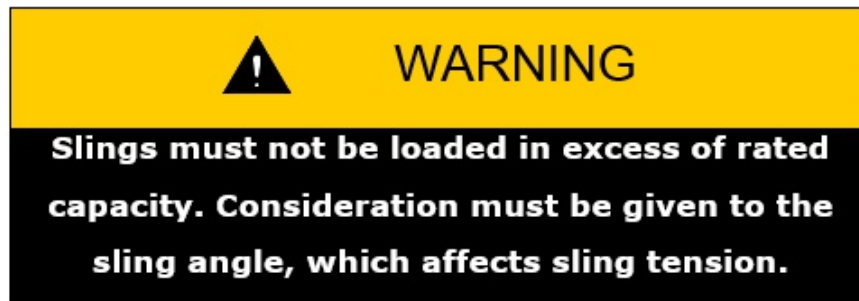
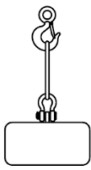
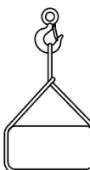
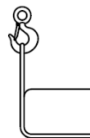
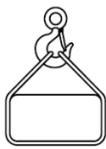

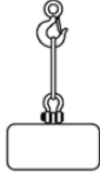

Table 7. Rated Capacities for Polyester Roundslings

Roundsling Size / #	Color	 VERTICAL		 CHOKER		 VERTICAL BASKET		 45° BASKET	
		Lbs.	Kgs	Lbs.	Kgs	Lbs.	Kgs	Lbs.	Kgs
1	Purple	2,600	1,200	2,100	1,000	5,200	2,400	3,700	1,700
2	Green	5,300	2,400	4,200	1,900	10,600	4,800	7,500	3,400
3	Yellow	8,400	3,800	6,700	3,000	16,800	7,600	11,900	5,400
4	Tan	10,600	4,800	8,500	3,800	21,200	9,600	15,000	6,800
5	Red	13,200	6,000	10,600	4,800	26,400	12,000	18,700	8,500
6	White	16,800	7,600	13,400	6,000	33,600	15,200	23,800	10,700
7	Blue	21,200	9,600	17,000	7,600	42,400	19,200	30,000	13,600
8	Orange	25,000	11,400	20,000	9,100	50,000	22,800	35,400	16,100
9	Orange	31,000	14,100	24,800	11,300	62,000	28,200	43,800	19,900
10	Orange	40,000	18,200	32,000	14,500	80,000	36,400	56,600	25,700
11	Orange	53,000	24,100	42,400	19,300	106,000	48,200	74,900	34,100
12	Orange	66,000	30,000	52,800	24,000	132,000	60,000	93,000	42,400
13	Orange	90,000	40,900	72,000	32,700	180,000	81,800	127,300	57,800

*\*Caution:*

*Color codes and rated capacities may vary among manufacturers. ALWAYS CHECK THE IDENTIFICATION TAG TO DETERMINE IF THE POLYESTER ROUNDSLING RATED CAPACITY IS APPLICABLE FOR THE LIFT.*

**Table 8. Rated Capacities for High Performance Yarn (HPY) Roundslings**

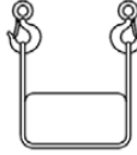
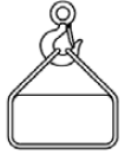
	 VERTICAL		 CHOKER		 VERTICAL BASKET		 45° BASKET	
	Lbs.	Kgs	Lbs.	Kgs	Lbs.	Kgs	Lbs.	Kgs
1H	10,000	4,600	8,000	3,700	20,000	9,100	14,100	6,400
2H	15,000	6,900	12,000	5,500	30,000	13,700	21,200	9,700
3H	20,000	9,100	16,000	7,300	40,000	18,200	28,300	12,900
4H	25,000	11,400	20,000	9,100	50,000	23,000	35,400	16,100
5H	30,000	13,700	24,000	10,900	60,000	28,000	42,400	19,300
6H	40,000	18,200	32,000	14,600	80,000	37,000	56,600	26,000
7H	50,000	23,000	40,000	18,200	100,000	46,000	70,700	33,000
8H	60,000	27,000	48,000	21,800	120,000	55,000	84,800	39,000
9H	70,000	32,000	56,000	26,000	140,000	64,000	99,000	45,000
10H	80,000	36,000	64,000	30,000	160,000	73,000	113,000	52,000
11H	90,000	41,000	72,000	33,000	180,000	82,000	127,000	58,000
12H	100,000	45,000	80,000	37,000	200,000	91,000	141,000	64,000
13H	125,000	57,000	100,000	46,000	250,000	114,000	177,000	81,000
14H	150,000	68,000	120,000	55,000	300,000	137,000	212,000	97,000
15H	175,000	79,000	140,000	64,000	350,000	159,000	247,000	113,000
16H	200,000	91,000	160,000	73,000	400,000	182,000	283,000	129,000
17H	225,000	102,000	180,000	82,000	450,000	205,000	318,000	145,000
18H	250,000	113,000	200,000	91,000	500,000	227,000	354,000	161,000
19H	275,000	125,000	220,000	100,000	550,000	250,000	389,000	177,000
20H	300,000	136,000	240,000	109,000	600,000	273,000	424,000	193,000
21H	400,000	181,000	320,000	146,000	800,000	363,000	566,000	257,000
22H	500,000	227,000	400,000	182,000	1,000,000	454,000	707,000	321,000
23H	600,000	272,000	480,000	218,000	1,200,000	546,000	848,000	386,000

## Section 5.2 Choosing Proper Connection Hardware (Polyester Roundslings)



This section covers hardware selection for polyester roundslings.

(For HPY roundslings, follow the sling manufacturers guidelines.)

Connection hardware should be selected such that it either:

- Conforms to the size requirements listed in Tables 9 and 10.

**OR**

- Sized such that that the bearing stress value at the connection does not exceed 7,000 Lbs./in<sup>2</sup> during sling loading. (See below).

**Table 9. Suitable Vertical or Choker Hitch Connection Hardware Sizes for Polyester Roundslings**

Roundslings		Hardware Size	
WSTDA Roundslings Size	Rated Capacity - Vertical Hitch (Lbs.)	Minimum Stock Diameter or Thickness (Inches)* <sup>2</sup>	Minimum Effective Contact Width* <sup>3</sup> (Inches) * <sup>2</sup>
1	2,600	7/16	1
2	5,300	5/8	1 3/8
3	8,400	3/4	1 3/4
4	10,600	7/8	1 7/8
5	13,200	1	2
6	16,800	1 1/8	2 1/8
7	21,200	1 3/16	2 5/8
8	25,000	1 1/4	2 7/8
9	31,000	1 1/2	3 1/4
10	40,000	1 5/8	3 5/8
11	53,000	2	4
12	66,000	2 1/8	4 5/8
13	90,000	2 1/2	5 1/4

**Table 10. Suitable Basket Hitch Connection Hardware Sizes for Polyester Roundslings\***

Roundslings		Hardware Size	
WSTDA Roundslings Size	Rated Capacity - Basket Hitch (Lbs.)	Minimum Stock Diameter or Thickness (Inches)* <sup>2</sup>	Minimum Effective Contact Width* <sup>3</sup> (Inches) * <sup>2</sup>
1	5,200	9/16	1 3/8
2	10,600	7/8	1 7/8
3	16,800	1 1/16	2 3/8
4	21,200	1 1/4	2 1/2
5	26,400	1 3/8	2 7/8
6	33,600	1 5/8	3
7	42,400	1 5/8	3 3/4
8	50,000	1 7/8	4
9	62,000	2	4 1/2
10	80,000	2 3/8	5
11	106,000	2 3/4	5 5/8
12	132,000	3	6 1/2
13	180,000	3 1/2	7 3/8

\*The values in Table 10 apply to the use of roundslings in a basket hitch when the two ends of the sling are attached to a single connection point. Use Table 9 when roundslings are used in a basket hitch when the two ends of the sling are attached to separate connection points.

\*<sup>2</sup>These values are rounded up the closest fractional equivalent.

\*<sup>3</sup>These values also equal the approximate natural flattening width of the roundslings.

### Section 5.3 Bearing Stress Calculations for Polyester Roundslings (If Needed)

For most applications, Tables 9 and 10 can be used to adequately verify suitability of hardware connections. However, a more thorough review of hardware suitability is sometimes needed. Using this calculation is most commonly helpful when the diameter or width of the hardware is smaller than listed in Tables 9 and 10, but the actual loading on the polyester roundslings is less than the full capacity of the sling.

*Calculating Bearing Stress Values at the Hardware Connection* – The bearing stress value at any connection is determined by dividing the amount of loading on the sling by the load bearing area at the hardware connection. As the size of the connection hardware increases, the bearing stress value will be reduced. *For polyester slings*, the hardware must be sized large enough to *keep the bearing stress value at the connection to less than 7,000 Lbs. /in<sup>2</sup>* during sling loading. The standard recommended hardware size for each sling is based on each sling being tensioned to its full rated capacity. However, whenever the sling is tensioned to lower tension values, the size of the connection hardware can often be reduced when using the following calculations.

Bearing Stress Calculation:

$$\text{Bearing Stress} = \frac{\text{Sling Load Value}}{\text{Load Bearing Area}}$$

Where,

*Load Bearing Area at the Hardware Connection* - The load bearing area at the hardware connection is determined by multiplying the thickness or stock diameter of the hardware by the effective contact width at the connection.

$$\text{Load Bearing Area} = (\text{Hardware Thickness or Stock Diameter}) \times (\text{Effective Contact Width})$$

**Effective Contact Width between the Sling and Connection Hardware**

- a. **Connection to Flat-Bottom Surfaced Hardware** – Hardware connections with flat bottoms include pins, bolts and trunnions. The value of the effective contact width is equal to the opening width or spread of the sling at the connection area (See Figure 25). Please note, however, that the effective contact width will never exceed the natural flattening width of each sling, which are as listed in Tables 9 and 10 as the Minimum Effective Contact Width. For example, if a Size 2 polyester roundsling is connected to hardware that has a relatively large inside width, such as 4 inches, the effective contact width between the sling and hardware will not be higher than the natural flattening width of the sling, which is listed in Table 9 as being 1-3/8 inches.

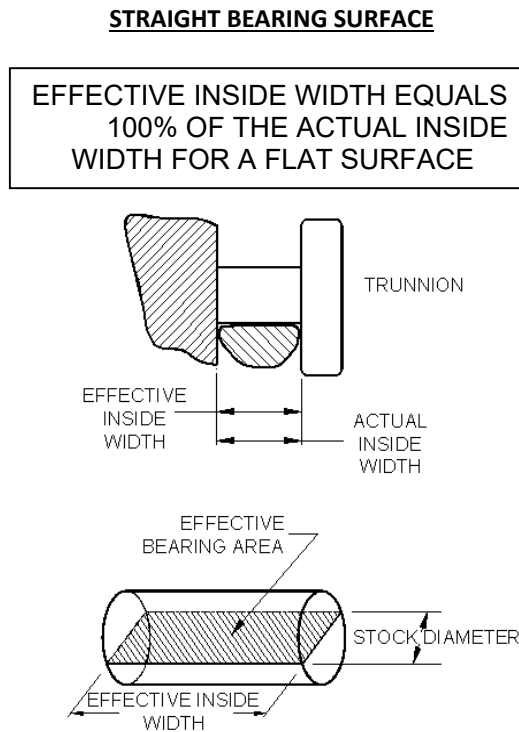

Figure 25

- b. *Connection to Round-Bottom (or Curved) Surfaced Hardware* – Hardware connections with curved shaped connections include links, hooks, and the bow ends of shackles. To determine the value of the effective contact width, multiply the inside opening width of the hardware by a factor of .75 (See Figure 26). For connections to the base of hooks, multiply the value of the radius at the hook base by a factor of 1.5 to determine the effective contact width. Please note, however, that the effective contact width will never exceed the natural flattening width of each sling, which are as listed in Tables 9 and 10 as the Minimum Effective Contact Width. For example, if a Size 2 polyester roundsling is connected to hardware that has a relatively large inside width, such as 4 inches, the effective contact width between the sling and hardware will not be higher than the natural flattening width of the sling, which is listed in Table 9 as being 1-3/8 inches.

**CURVED BEARING SURFACE**

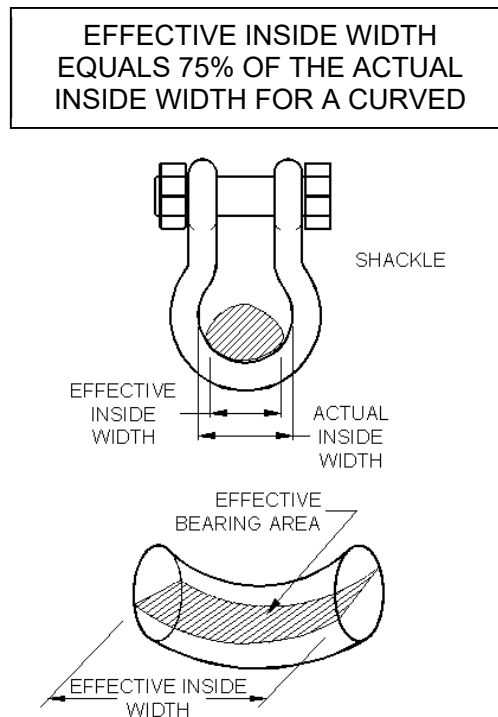

Figure 26

**Note:**

*Roundsling strength is affected by the size of the connection hardware. For special applications wherein a specific design factor is required to be maintained during the lift, please refer to the WSTDA Recommended Standard Specification for Synthetic Polyester Roundslings – RS-1.*

**Example:** A size 3 polyester roundsling, rated at 8,400 lbs. in a vertical hitch, is connected in a vertical hitch using the rounded bow end of a shackle that is smaller in size to that listed in Table 9. The shackle has a stock diameter of only .62 inch, and an inside opening width of 2 inches. However, a force of only 6,000 lbs. is applied, noticeably less than the rated capacity of the sling (See Figure 27).

**Question** - Is this use of the selected shackle acceptable?

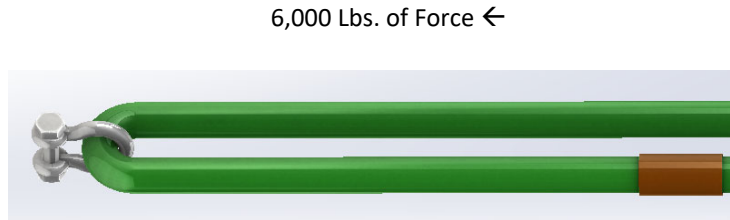

Figure 27

**Answer:** Since the shackle size is smaller than recommended for a size 3 roundsling per Table 9, we need to establish that the bearing stress value does not exceed 7,000 Lbs. /in<sup>2</sup> during use.

Since the shackle bearing surface is rounded, multiply the width by .75 to determine the Effective Contact Width (See below Contact Width Info.):

$$\begin{aligned} \text{Effective Contact Width} &= \\ & (.75) \times (\text{The shackle inside width}) = (.75) \times (2 \text{ inches}) \\ & = \mathbf{1.50 \text{ inches}} \end{aligned}$$

And;

$$\begin{aligned} \text{Load Bearing Area} &= \\ & (\text{The shackle stock diameter}) \times (\text{The Effective Contact Width}) \\ & = (.62 \text{ inches}) \times (1.50 \text{ inches}) = \mathbf{.93 \text{ in}^2} \end{aligned}$$

$$\begin{aligned} \text{Bearing Stress Value} &= \\ & (\text{The Applied Force}) / (\text{Load Bearing Area}) \\ & = (6,000 \text{ Lbs.}) / (.93 \text{ in}^2) \\ & = \mathbf{6,451 \text{ Lbs. / in}^2} \end{aligned}$$

Therefore, since the bearing stress value is less than 7,000 Lbs. /in<sup>2</sup> during use, **the selected shackle size is suitable for use.**

## Section 5.4 Protecting Roundslings from Being Cut or Damaged from Contact with Edges

This section addresses the following topics:

- When do roundslings need cut protection?
- What form of cut protection is suitable?

### The Number One Cause of Sling Accidents!

*Synthetic type slings can become cut* or damaged if they are allowed to come into direct contact with edges if the edges are not suitably well rounded. Such edges can include both the edges of the load as well as the edges of the connection hardware.



## Section 5.5 When do Roundslings Need Cut Protection?

Surfaces in contact with the sling do not have to be very abrasive or have “razor” sharp edges in order to create the conditions for sling failure.

The strength of roundslings are significantly affected, and sling protection must be used whenever the edges of the load or connection hardware do not meet the requirements specified in the following:

*Required Radius of Rounded Edges* – Roundslings shall be properly protected from rounded edges if the size of the edge radius is not adequately large. The required size of the edge radius, depends on the sling capacity, and increases with the size of the sling. Unless prescribed differently by the sling manufacturer, see Tables 11 and 12 for the listed minimum edge radius values appropriate for each size roundslings. These values hold true regardless of the type of hitch being used.

*Measuring the radius of an edge* – One method of measuring an edge radius is noted in the following:

Place the leading edge of the ruler or tape measure along the leading edge of the radius that is being measured (Point A). Measure the distance from this leading edge, Point A, to the point where the radius initiates from the bottom edge of the surface, Point B (See Figure 28). In this figure, a radius of 1/2" is shown.

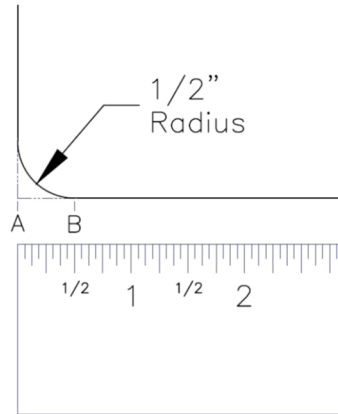

Figure 28

*Note: A chamfered Edge is not an equivalent Substitute* - Roundslings shall be properly protected from edges that are not smoothly rounded. This includes chamfered edges.

Roundslings shall only be allowed to come into direct contact with edges if they are smooth and are well rounded to a suitable edge radius. Direct contact of roundslings with edges that are machined at an angle, such as a 45-degree angle, can cut into the sling and significantly reduce sling strength. Roundslings shall not be allowed to come into direct contact with edges that are chamfered, or flattened at an angle, unless the edges conform to edge radius requirements, as noted below. (See Figure 29)



Figure 29 Inappropriate Direct Contact of Unprotected Roundslings with a Chamfered Edge

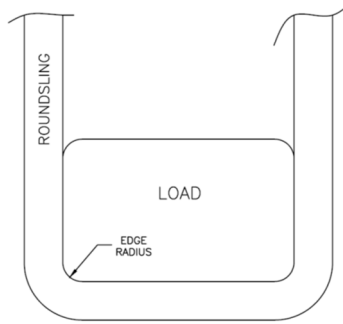

Figure 30

**Table 11. Minimum Edge Radii suitable for contact with unprotected Polyester Roundslings\***

Sling Size	Vertical Rated Capacity (Lbs.)	Minimum Edge Radii (Inches)	Sling Width at Load (Inches)	Minimum Edge Radii** (Inches)
1	2,600	0.14	.97	<b>3/16</b>
2	5,300	0.21	1.29	<b>1/4</b>
3	8,400	0.26	1.66	<b>5/16</b>
4	10,600	0.30	1.78	<b>5/16</b>
5	13,200	0.33	2.00	<b>3/8</b>
6	16,800	0.40	2.13	<b>7/16</b>
7	21,200	0.41	2.62	<b>7/16</b>
8	25,000	0.44	2.85	<b>7/16</b>
9	31,000	0.50	3.15	<b>1/2</b>
10	40,000	0.56	3.57	<b>9/16</b>
11	53,000	0.67	4.00	<b>11/16</b>
12	66,000	0.72	4.60	<b>3/4</b>
13	90,000	0.87	5.22	<b>7/8</b>

**Table 12. Minimum Edge Radii suitable for contact with unprotected HPY Roundslings\***

<b>Sling Size Number</b>	<b>Vertical Rated Capacity (Lbs.)</b>	<b>Minimum Edge Radii (Inches)</b>	<b>Minimum Edge Radii** (Inches)</b>
1H	10,000	.43	<b>7/16</b>
2H	15,000	.50	<b>1/2</b>
3H	20,000	.63	<b>5/8</b>
4H	25,000	.69	<b>11/16</b>
5H	30,000	.75	<b>3/4</b>
6H	40,000	.88	<b>7/8</b>
7H	50,000	.88	<b>7/8</b>
8H	60,000	1.00	<b>1</b>
9H	70,000	1.13	<b>1 - 1/8</b>
10H	80,000	1.25	<b>1 - 1/4</b>
11H	90,000	1.25	<b>1 - 1/4</b>
12H	100,000	1.38	<b>1 - 3/8</b>
13H	125,000	1.50	<b>1 - 1/2</b>
14H	150,000	1.50	<b>1 - 1/2</b>
15H	175,000	1.75	<b>1 - 3/4</b>
16H	200,000	1.75	<b>1 - 3/4</b>
17H	225, 000	1.75	<b>1 - 3/4</b>
18H	250,000	2.00	<b>2</b>
19H	275,000	2.00	<b>2</b>
20H	300,000	2.25	<b>2 - 1/4</b>
21H	400,000	2.50	<b>2 - 1/2</b>
22H	500,000	3.00	<b>3</b>
23H	600,000	3.50	<b>3 - 1/2</b>

\*The radii values apply to the roundslings that are fully tensioned to their rated capacity. When roundslings are tensioned to lower force values, the minimum radius values will reduce accordingly.

\*\*Fractional equivalent, rounded up to the nearest 1/16".

## **Section 5.6 What Form of Cut Protection is Suitable?**

**Roundslings must ALWAYS be protected from being cut or damaged by corners, edges, protrusions or abrasive surfaces with protection sufficient for the intended purpose.** A host of sling protection products are available. Consider that some protection products provide good abrasion resistance, but offer little protection against cutting, while some others are specifically designed and test engineered to protect slings against cutting.

The goal is to ensure that the sling, while under tension, will maintain its ability to securely handle the load while

avoiding contact with damaging or abrasive surfaces under tension. Regardless of the approach taken, a qualified person must ensure that the protection method chosen is appropriate for the application. You should keep in mind that no protection is “cut proof” and you should always operate within the specified limits of the sling and its accessories (e.g., fixtures, hardware, protection, etc.).

### Test Lift Verification

When first verifying suitability of the protection, perform one or more “test” lifts, done in a non-consequence setting, to assist in determining the suitability of the protection device(s). After each “test” lift, the protection device(s) and the sling(s) will need to be inspected for damage and suitability.

**Table 13. Issues and Risk Factors to Consider**

Safe handling, lifting and manipulation of materials and loads requires consideration of a number of factors and issues, including (but not limited to):			
Categories	A Number of Issues/Factors to Consider		
Environment	Wind Weather Visibility	Environmental temperature Object temperature Chemical conditions and exposure	Ground stability Underground installations
Load	Weight Dimensions Center of Gravity (CG)	Attachment point integrity Susceptibility to crushing/compression Loose parts that could fall from load	Combination loads Damaging surfaces/edges Structural stability (bend/flex)
Equipment/Lift	Single/multiple cranes/hoists Maximum/planned operating radius Allowable load Ratio of lift to allowable load	Clearance to surrounding facilities Power lines and other environmental hazards Clearance between boom and lift Emergency/contingency set down area	Equipment inspection Ensure a clear load path
Rigging	Sling selection Load control Lift point (over the CG) Positive sling-to-load engagement	Coefficient of friction: Sling-to-load Appropriate hitch (for CG and load control) Load is free to move and is not snagged Coordination of multiple slings	Suitable wear protection Sling capacity is adequate for angle and tension
Personnel	Area clear of unnecessary personnel Personnel are trained and qualified	Signals: Visual, audible, electronic, etc. Personnel away from load and other dangers	Pre-lift plan and meeting Tag lines/spotter requirements

## Section 5.7 Other Mechanical Considerations

- **Roundslings in contact with edges, corners, or protrusions MUST ALWAYS be protected with materials of sufficient strength, thickness, and construction to prevent sling damage.**
- Roundslings should be protected from abrasive surfaces.
- Determine the weight of the load. Roundslings shall not be loaded in excess of the rated capacity. Consideration shall be given to the sling angle, which affects rated capacity. (See Effect of Sling Angle Section).
- Select roundslings having suitable characteristics for the type of load, hitch and environment.

- Roundslings with fittings that are used in a choker hitch shall be of sufficient length to ensure that the choking action is on the roundsling, and never on the fitting, or sling tag.
- The openings in fittings shall be the proper shape and size to ensure that the fittings will seat properly on the roundsling, crane hook, or other attachments.
- Roundslings should not be dragged on the floor or over an abrasive surface.
- A half twist (up to 180°) may be applied to any roundsling to facilitate its attachment. However, roundslings must not be twisted further or be tied into knots to shorten their length or be joined to another roundsling by knotting them together. Roundslings shall be shortened, lengthened or adjusted only by methods approved by the manufacturer.
- Roundslings should not be pulled from under loads when the load is resting on the roundsling. Place blocks under load prior to setting down the load, to allow removal of the sling, if applicable.
- Roundslings shall not be used to pull against stuck, snagged or restrained objects.
- Do not drop roundslings equipped with metal fittings.
- Roundslings that are damaged shall not be used.
- Roundslings shall be hitched in a manner providing control of the load. Roundslings used in a basket hitch shall have the load balanced to prevent slippage.
- Shock loading shall be avoided.
- Load applied to a hook shall be centered in the bowl of the hook to prevent point loading.
- During use, personnel shall be alert for possible snagging of the load or roundsling.
- The roundsling legs (branches) shall contain or support the load from the sides above the center of gravity when using a basket hitch.
- Tags and labels should be kept away from the load, hook and point of choke.
- Roundslings should not be constricted or bunched between the ears of a clevis or shackle, or in a hook. When a roundsling is used with a shackle, it is recommended that it be used (rigged) in the bow of the shackle. When this is not possible, protect the sling connection areas from damage.
- For lifts using multiple slings, or multiple-leg bridle slings, on nonsymmetrical loads, an analysis by a qualified person should be performed to prevent overloading of any leg.
- Place blocks under load prior to setting down the load, to allow removal of the roundsling, if applicable. Do not

pull slings from under loads when the load is resting on them.

- For multiple-leg slings used with nonsymmetrical loads, an analysis by a qualified person should be performed to prevent overloading of any leg.
- Do not use hooks, shackles or other hardware that have edges or surfaces that could damage the sling.
- Do not run or drive over slings with a vehicle or other equipment.

## Section 5.8 Environmental Considerations

Environmental factors such as an exposure to sunlight, dirt or gritty-type matter and cyclical changes in temperature and humidity, can result in an accelerated deterioration of roundslings. The rate of this deterioration will vary with the level of exposure to these conditions.

*Temperature Limits* – Do not expose roundslings to sources of heat damage or weld splatter.

- Polyester Roundslings shall not be used in contact with objects or in environments at temperatures in excess of 194° F (90° C), or at temperatures below minus 40° F (-40° C).
- HPY Roundslings must not be used in contact with objects or in environments at temperatures above:
  - 158°F (70 °C) for roundslings with 100% HMPE load bearing core yarn. \*
  - 350°F (175 °C) for roundslings with 100% aramid load bearing core yarn. \*
  - For HPY Roundslings using blended load bearing core materials or other core yarn materials types not listed, consult the manufacturer.
- For short term, single exposure applications at temperatures elevated slightly higher than the above values, sling users may consult with the sling manufacturer and seek written approval to allow this practice.

\* Actual temperature limits may vary with specific material grades.

*Chemical Environment* – Do not expose slings to damaging chemicals. Chemically active environments can affect the strength of roundslings in varying degrees ranging from little to total degradation. The roundsling manufacturer or qualified person should be consulted before roundslings are used in a chemically active environment. Each chemical application shall be evaluated, taking into consideration the following:

- A. Type of chemical, such as acid or alkalis
- B. Exposure conditions, i.e., liquid, vapor, mist

- C. Concentration
- D. Temperature
- E. Duration of exposure

Roundslings incorporating aluminum fittings shall not be used where fumes, vapors, sprays, mists or liquids of alkalis and/or acids are present, unless the compatibility of these material is verified.

#### *Electrical Environment –*

Do not expose roundslings to an electrically active environment or use them as an electrical insulator in an energized electrical environment unless a qualified person has determined the insulation requirements necessary for the application and has established that use of a particular sling will meet the requirements for their purpose.

Otherwise, severe injury or death can result from shock, burns or electrocution. Consideration shall also be given to the effect of other environmental factors, including humidity, on the slings capability for this purpose.

## **CHAPTER 6: ROUNDSLING REPAIR**

There shall be no repairs of load bearing fibers.

Repairs to the protective covers shall be done only by the original manufacturer or their appointed agent. When slings are repaired by someone other than the original manufacturer, the sling should be tagged to identify the repair agent.

Only roundslings which can be identified from the information on the identification tag shall be repaired.

All repaired roundslings shall be proof tested to a minimum of two (2) times the rated capacity before being put back into service. Certification of proof test should be provided.

## **CHAPTER 7: SLING STORAGE AND MAINTAINANCE**

Roundslings should be stored in a cool, dry, and dark place to prevent loss of strength when not in use through exposure to ultraviolet rays. Roundslings shall not be stored in chemically active areas.

# WEB SLING & TIE DOWN ASSOCIATION PUBLICATIONS

## ***Recommended Standard Specifications for:***

- Synthetic Web Slings (WSTDA-WS-1)
- Synthetic Polyester Roundslings (WSTDA-RS-1)
- High Performance Yarn (HPY) Roundslings (RS-1HP)
- Synthetic Webbing for Slings (WSTDA-WB-1)
- Sewing Threads for Slings & Tie Downs (WSTDA-TH-1)
- Synthetic Web Tie Downs (WSTDA-T-1)
- Winches Used With Web Tie Downs (WSTDA-T-3)
- Synthetic Webbing Used for Tie Downs (WSTDA-T-4)
- Load Binders Used with Chain Tie Downs (WSTDA-T-6)
- Strength & Elongation Test Method for Sling & Tie Down Webbing (WSTDA-TM-1)

## ***Operating, Care & Inspection Manuals for:***

- Synthetic Web Slings (WSTDA-WS-2)
- Synthetic Polyester Roundslings (WSTDA-RS-2)
- Synthetic Web Tie Downs (WSTDA-T-2)

***Download free, single-use copies of the above Standards and Manuals at [www.wstda.com](http://www.wstda.com)***

***Available for Purchase from Web Sling & Tie Down Association:***

## ***Warning Products: Available in English, Spanish and French***

- Warning Labels: Web Slings, Roundslings, High Performance Yarn Roundslings, Web Tie Downs
- Safety Bulletins: Web Slings, Roundslings, High Performance Yarn Roundslings, Web Tie Downs

## ***Illustrated Wall Chart***

- Inspection of Web Slings & Roundslings (WSTDA-WSWC-1)

## ***UV Degradation Reports***

- UV Degradation Testing Program for Web Slings: Summary Report (2003) (WSTDA-UV-Sling-2003)
- UV Degradation Testing Program for Web Slings: Graphs (Mini Manual) (WSTDA-UV-MM-2005)
- UV Degradation Testing Program for Web Slings: Report (1981, revised 2005) (WSTDA-UVDR-1981)

***For ordering information and prices, contact the association office or visit our website:***

**Web Sling & Tie Down Association, Inc.**  
2331 Rock Spring Road, Forest Hill, Maryland 21050  
Phone (443) 640-1070  
Fax (443) 640-1031  
Email: [wstda@stringfellowgroup.net](mailto:wstda@stringfellowgroup.net)  
Web Site: [www.wstda.com](http://www.wstda.com)

